

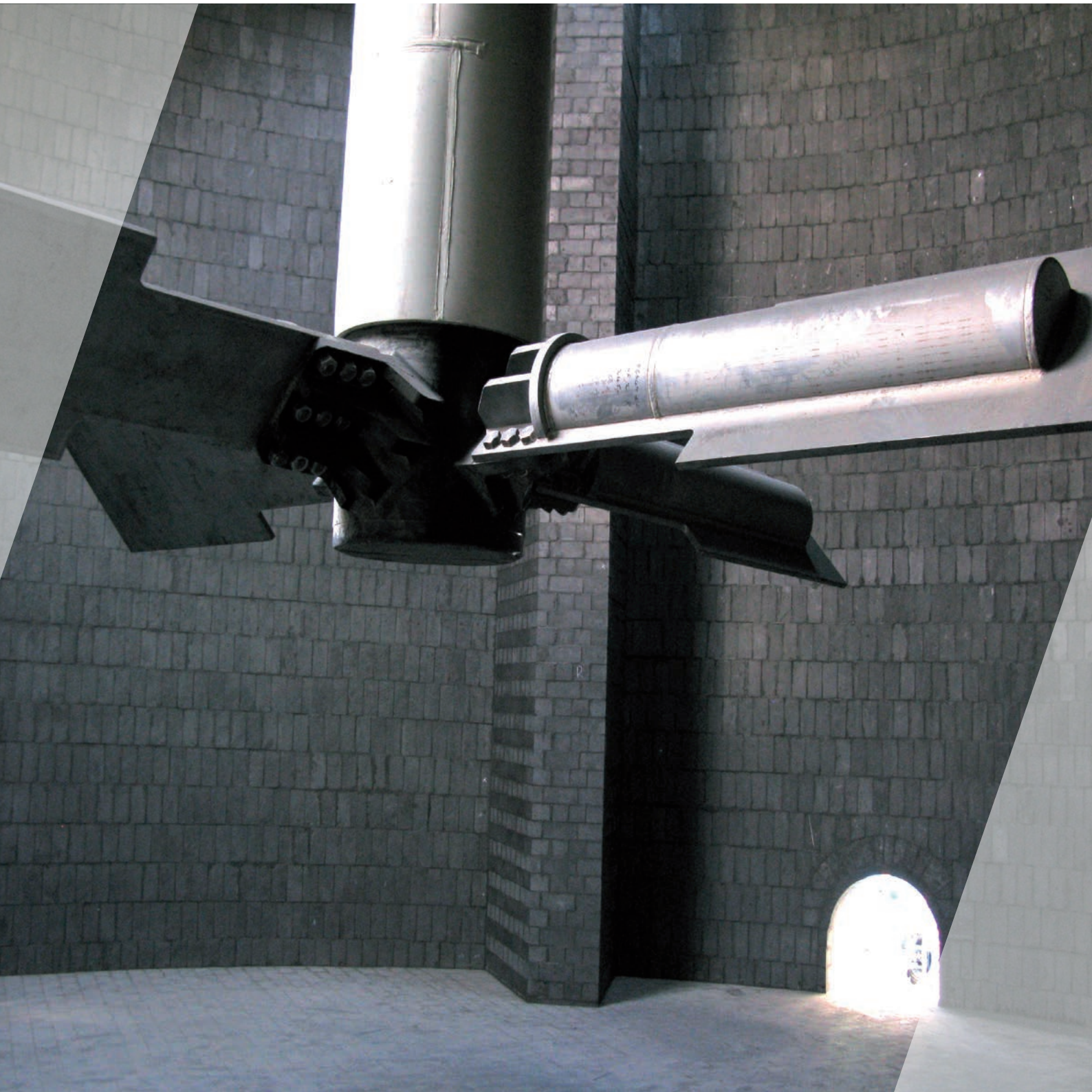

// ONE BRAND // ONE SOURCE // ONE SYSTEM



// SERVICE // MATERIAL PROCESSING // SURFACE PROTECTION // AUTOMOTIVE

REMA TIP TOP BRICK LINING SYSTEMS



## REMA TIP TOP BRICK LINING SYSTEMS

**From professional advice on materials, construction and design to qualified installation - competent service from a single source.**

REMA TIP TOP brick and tile linings reliably protect your plant, process vessels and storage tanks against chemical attack and corrosion.

In chemical process technologies or flue gas cleaning, in addition to exposure to chemicals, high thermal and mechanical wear often occur. Under these extreme conditions, our proven lining systems themselves need additional effective protection, to be able to perform their task safely and over the long term.

We ensure this protection by a well engineered system of acid-proof brick linings – always exactly suited to the plant's specific conditions.

Combined system build-ups are matched perfectly to the membrane – whether rubber lining or synthetic resin-based coating – consisting of acid-proof bricks, carbon bricks, graphite or insulating bricks or wear-resistant ceramics, ensuring maximum service life and a cost-effective return.

On the basis of exact analysis of chemical and thermal exposure and mechanical or abrasive stresses, and by means of heat transfer calculations, suitable build-ups using appropriate materials will be engineered, matching the overall process control.

Apart from tiles, standard formats and shaped bricks, our bedding and jointing mortars ensure the construction of the combined system.

Whether they are pickling plants, autoclaves, sulfuric acid towers, reactors in phosphoric acid plants or quenches, we have a broad and versatile portfolio of mortar materials which cover a wide range of applications.

- **bonding agents based on furan or phenolic resins**
- **unsaturated polyester resins**
- **vinyl ester resins**
- **epoxy resins**
- **or potassium silicate**

In combination with high-quality inert fillers on quartz or carbon basis, they ensure optimum adhesion to the impermeable membrane layer and a strong bond, always with the maximum chemical resistance.

Depending on the level of exposure, products from the CHEMOKITT Series or the worldwide proven Asplit® Series will be used.

Often high-alloy stainless steels are not suitable under certain process conditions. In that case our long-term proven acid proof brick linings are the ideal solution to achieve an economical service life of your plant.



Brick lining with CHEMOKITT FU 1310



# REMA TIP TOP BRICK LINING SYSTEMS

## BRICK LINED HYDROCHLORIC PICKLING TANK



### Build-up of lining

1. Steel, blasted
2. CHEMOLINE 70 CN
3. CHEMOKITT FU 1310
4. Acid proof ceramic bricks, 65 mm

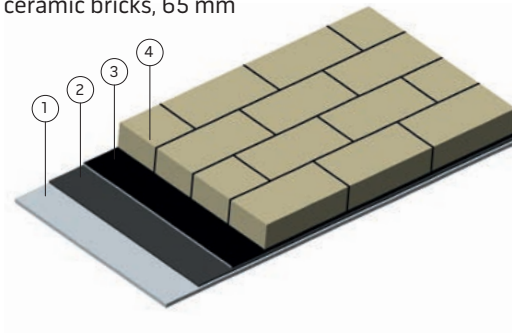

## VESSELS FOR THE PHOSPHORIC ACID INDUSTRY



### Build-up of lining

1. Steel, blasted
2. CHEMOLINE 4B
3. CHEMOKITT FU 1320
4. Carbon bricks, 65 mm

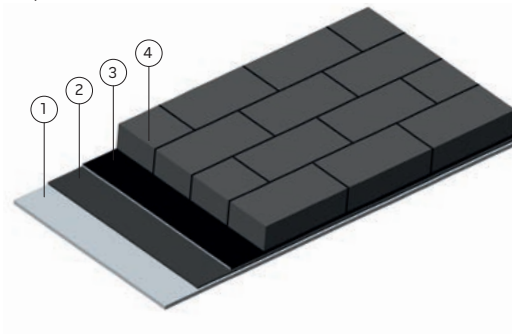

Brick lining a tank floor with Asplit CN

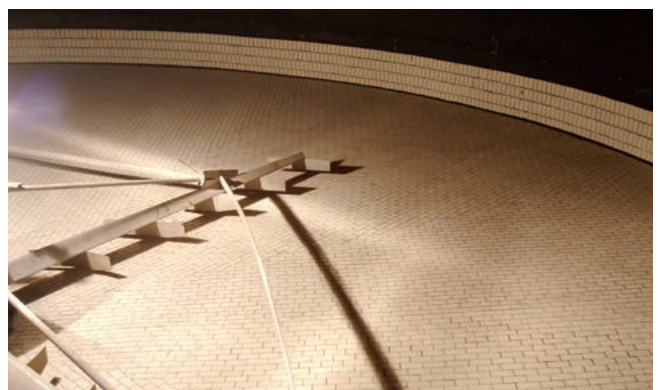

Brick lining in a thickener for protection of the rubber membrane against mechanical abrasion.

# REMA TIP TOP BRICK LINING SYSTEMS

At REMA TIP TOP, all available brick formats and qualities are cataloged as shown in the following sketches. Using the latest CAD technology, we are furthermore able to present promptly complex constructions and meet customer requirements down to the last detail.

08 € Acid-proof shell bricks

Abbreviation	R	Weight kg/pc.					
		s=30	s=40	s=50	s=65	s=80	s=100
M8	400	2,26	2,97	3,66	4,67	5,63	6,85
		08001	08002	08003	08004	08005	08006
		2,29	3,03	3,75	4,81	5,84	7,00
M12	600	08007	08008	08009	08010	08011	08012
		2,30	3,05	3,79	4,88	5,94	7,16
		08013	08014	08015	08016	08017	08018
M20	1000	2,31	3,08	3,82	4,93	6,01	7,26
		08019	08020	08021	08022	08023	08024
		2,33	3,10	3,86	4,98	6,11	7,41
M30	1500	08025	08026	08027	08028	08029	08030

© June 2013  
Revision: Date: Designer: Checked: Approved:

16 € Acid-proof runners

Designation: R1  
Weight: 14,40kg/pc.  
Item code: 16001

Designation: R2  
Weight: 11,50kg/pc.  
Item code: 16002

© June 2013  
Revision: Date: Designer: Checked: Approved:

101 € Tank nozzle with ceramic sleeve (special version)

DN	Pipe		Ceram. sleeve	
	d1	s1	da	s
80	159,0	4,5	120	20
	168,3	4,5	130	25
	193,7	5,4	150	35
100	193,7	5,4	160	40
	219,1	5,9	180	40
	219,1	5,9	180	27,5
125	267,0	6,3	220	47,5

DN	pipe		Ceram. sleeve	
	d1	s1	da	s
150	267,0	6,3	220	35
	273,0	6,3	230	40
200	323,9	7,1	280	40
	250	368,0	8,0	320
300	406,4	8,0	360	30

© June 2013  
Revision: Date: Designer: Checked: Approved:

Whether you want to use a cleaning device to remove gypsum deposits in an absorber or operate a quench with a 700 °C flue gas inlet temperature or plan a sulfuric acid drying tower with a ceramic self-supporting dome, we are able to offer you a customized solution to meet your needs, consisting of rubber linings or coatings combined with REMA TIP TOP brick linings – both long-lasting and cost effective.



Self-supporting ceramic dome

Above and beyond protection against thermal and mechanical stresses, brick linings offer improved chemical resistance since they reduce the direct contact of the medium to the impermeable membrane layer.

Besides the optimal material choice consisting of CHEMOLINE or CHEMONIT rubber linings, respectively coatings such as COROFLAKE or LINING in combination with high-quality bricks and mortars only achieve a truly high quality lining through the design tailored to suit the most complicated geometries.

Our experienced constructors design every detail based on CAD drawings and define exactly how every single brick ties into one another to support the complete acid-proof lining, which represents quality – brick by brick.

Efficient site planning minimizes assembly times, the flexibility that characterizes our project management and how we handle projects on-site – these are things we practice in nearly all countries of the globe.

A functional lining quality is achieved in many small steps:

- own research and development
- own production with products matched to one another
- professional advice and design
- premium quality installation and site management

→ REMA TIP TOP service from a single source

# DESIGN EXAMPLE OF A LINING QUENCH TOWER

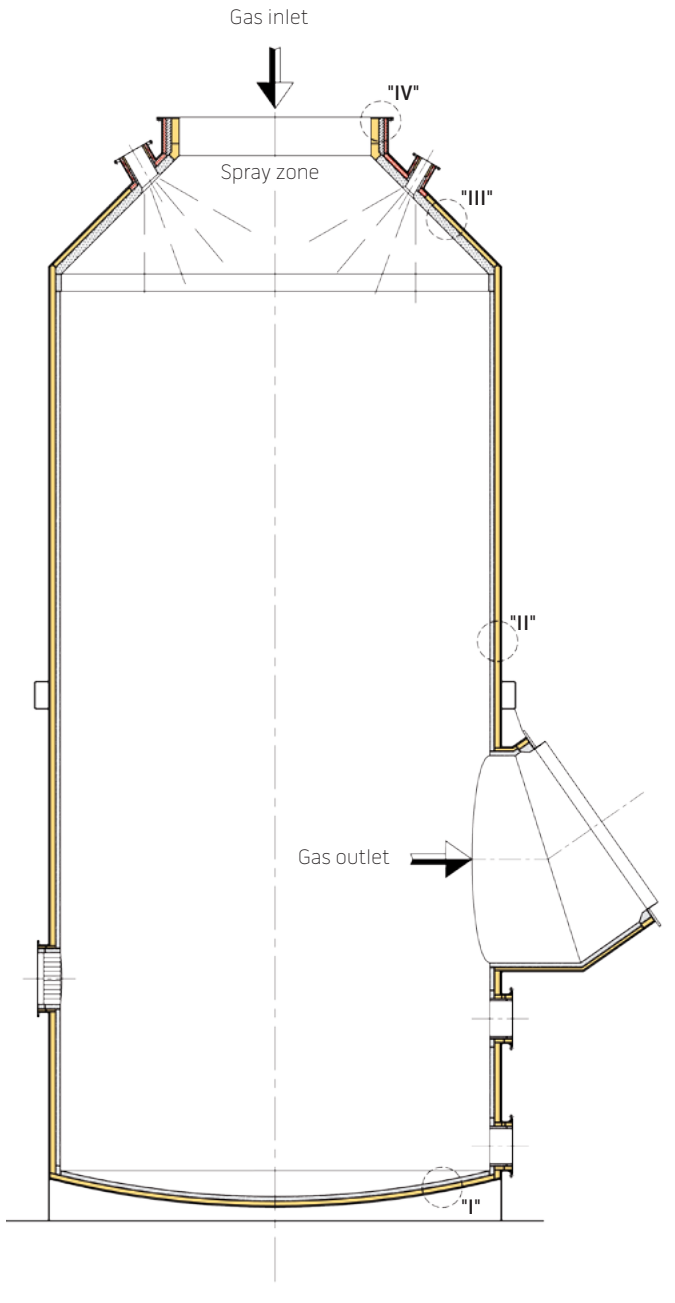

Typical I

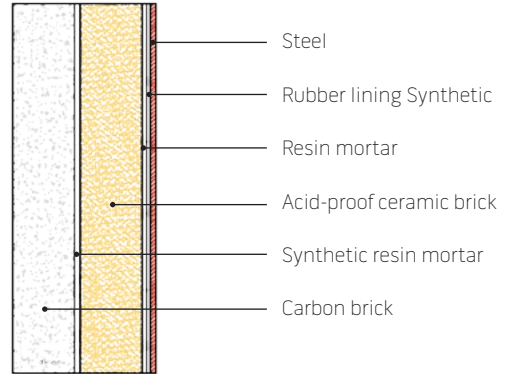

Typical II

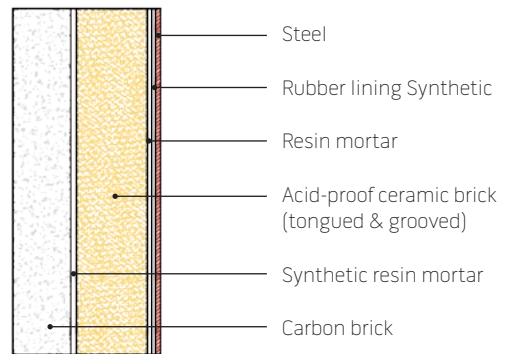

Typical III

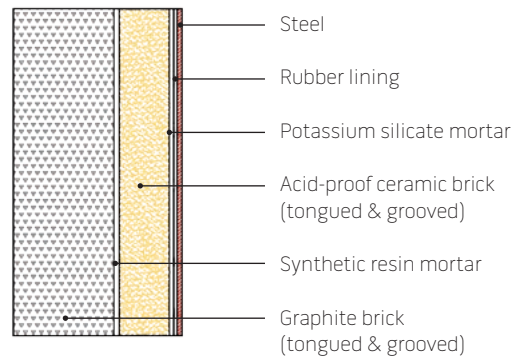

Typical IV

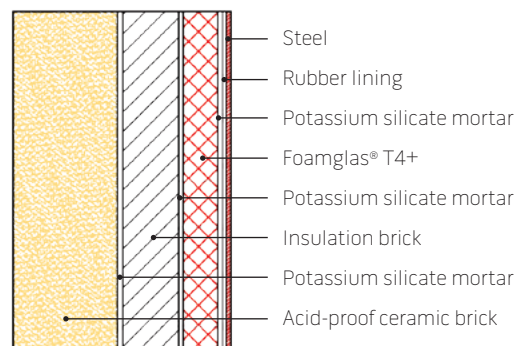

## CHEMOKITT SYNTHETIC RESIN MORTAR

Product	Polymer/ Binding agents	Application
<b>CHEMOKITT FU 1310</b>	Furan resin	<p><b>CHEMOKITT FU 1310</b> is a two-component, cold curing synthetic resin mortar, based on a furan resin with mineral fillers.</p> <p><b>CHEMOKITT FU 1310</b> is suitable as bedding and jointing mortar for ceramic tiles, bricks and fittings, especially at high chemical exposure to acids, alkalis or organic solvents and high temperature and mechanical stresses.</p> <p>Main applications are tiling and brick linings in equipment for the chemical industry, waste water and process water treatment, in channels, pits and sumps, power plants, warehouses and workshops, neutralization- and pickling lines.</p>
<b>CHEMOKITT FU 1320</b>	Furan resin	<p><b>CHEMOKITT FU 1320</b> is a two-component, cold curing synthetic resin mortar, based on a furan resin with carbon fillers. The cured, silicate-free resin is electrically dissipating.</p> <p><b>CHEMOKITT FU 1320</b> is suitable as bedding and jointing mortar for tiles, bricks and fittings made of acid-resistant ceramic, carbon or graphite material.</p> <p><b>CHEMOKITT FU 1320</b> is particularly suitable for high chemical loads of acids, including hydrofluoric acid, strong lyes and organic solvents at high temperature stresses. Main applications are tiling and brick linings in equipment for the chemical industry, waste water and process water treatment, in the phosphoric acid and sulphuric acid industry, in flue gas desulfurization plants, neutralization- and pickling lines. Due to its good electrical dissipation, <b>CHEMOKITT FU 1320</b> is recommended for areas, where sparking shall be avoided due to the possible risk of explosion.</p>
<b>CHEMOKITT UP 1320</b>	Polyester resin, Vinyl ester resin	<p><b>CHEMOKITT UP 1320</b> is a three-component, cold curing synthetic resin mortar, based on a combination of unsaturated polyester and vinyl ester resin, with carbon filler. The cured resin mortar is electrically dissipating.</p> <p><b>CHEMOKITT UP 1320</b> is suitable as bedding and jointing mortar for tiles, bricks and fittings, especially at high chemical stresses resulting from strong acids and mixed acids such as nitric-hydrofluoric acid mixtures. Main applications are tiling and brick linings in equipment for the chemical industry, metal industry, channels, pits, neutralization- and pickling lines.</p>
<b>CHEMOKITT VE 1310</b>	Vinyl ester resin	<p><b>CHEMOKITT VE 1310</b> is a 2-component cold-hardening synthetic resin mortar based on vinyl resin with mineral fillers.</p> <p><b>CHEMOKITT VE 1310</b> is suitable for use as a bedding and jointing mortar for tiles, bricks and shaped pieces, particularly when these are exposed to chemical stresses due to acids, solvents and oxidizing media while undergoing high temperatures and mechanical loading. The main applications are tilings and brick linings in chemical industry equipment, in waste and process water preparation, in the cellulose industry and in pickling tanks.</p>
<b>CHEMOKITT VE 1311</b>	Vinyl ester resin	<p><b>CHEMOKITT VE 1311</b> is a two-component, cold curing synthetic resin mortar, based on a vinyl ester resin with mineral fillers.</p> <p><b>CHEMOKITT VE 1311</b> is suitable as bedding and jointing mortar for tiles, bricks and fittings, especially for chemical stresses resulting from acids, solvents and oxidizing media. Furthermore, <b>CHEMOKITT VE 1311</b> has a high temperature and a high mechanical stress resistance. Main applications are tiling and brick linings in equipment for the chemical industry, waste water and process water treatment, the pulp and paper industry and in pickling lines.</p>
<b>CHEMOKITT WG 1310</b>	Potassium silicate	<p><b>CHEMOKITT WG 1310</b> is a two-component, halogen-free bedding and jointing mortar, based on potassium silicate.</p> <p><b>CHEMOKITT WG 1310</b> is suitable for bedding and jointing of ceramic tiles, bricks and fittings, especially for chemical stresses resulting from concentrated sulphuric acids and oxidizing materials with very high temperature stresses. Main applications are tiling and brick linings in equipment for the sulphuric acid industry and in flue gas desulfurization plants as well as drying towers, quench towers or Venturi scrubbers.</p>



## Asplit® SYNTHETIC RESIN MORTAR

Product	Polymer/ Binding agents	Application
<b>Asplit® CN</b>	Modified phenolic resin	<p>Asplit® CN is a two-component, cold curing synthetic resin mortar, based on a modified phenolic resin with carbon fillers.</p> <p>Asplit® CN is suitable for bedding and jointing of tiles, bricks and fittings made of ceramic or carbon for the production of chemical, thermal and mechanically resistant coatings and protective linings.</p>
<b>Asplit® CN 916</b>	Modified phenolic resin	<p>Asplit® CN 916 is a two-component, cold curing synthetic resin mortar, based on a modified phenolic resin with carbon fillers.</p> <p>Asplit® CN 916 is suitable for bedding and jointing of tiles, bricks and fittings made of ceramic or carbon for the production of chemical, thermal and mechanically resistant coatings and protective linings.</p>
<b>Asplit® FN</b>	Modified furan resin	<p>Asplit® FN is a two-component, cold curing synthetic resin mortar, based on a modified furane resin with inert carbon fillers.</p> <p>Asplit® FN is suitable for bedding and jointing of tiles, bricks and fittings made of ceramic or carbon for the production of chemical, thermal and mechanically resistant coatings and protective linings.</p> <p>Asplit® FN is particularly suitable for brick linings of chemical equipment (reactors, columns, scrubbers etc.) which are exposed to high temperatures and aggressive chemicals.</p>
<b>Asplit® VP 788</b>	Modified furan resin	<p>Asplit® VP 788 is a two-component, cold curing synthetic resin mortar, based on a modified furane resin with different fillers according to the use.</p> <p>Asplit® VP 788 is suitable for bedding and jointing of tiles, bricks and fittings made of ceramic or carbon for the production of chemical, thermal and mechanically resistant coatings and protective linings.</p>
<b>Asplit® HB</b>	Potassium silicate	<p>Asplit® HB is a halogen-free potassium silicate mortar made of two components.</p> <p>Asplit® HB is suitable for jointing of acid proof bricks, tiles, special fabricated pieces, for constructing apparatus and chimney linings.</p>
<b>Asplit® HES</b>	Potassium silicate	<p>Asplit® HES is a halogen-free potassium silicate mortar, which is prepared with water and hardens by chemical reaction. Binder and hardener are present in the mortar powder.</p> <p>Asplit® HES is used as mortar for fireclay-tubes in domestic chimneys. Furthermore it is suitable for full and open jointing of acid-proof bricks, tiles, special fabricated pieces for chimneys and apparatus linings.</p>
<b>Asplit® HSP</b>	Potassium silicate	<p>Asplit® HSP is a halogen-free potassium silicate mortar, which is prepared with water and hardens by chemical reaction.</p> <p>Asplit® HSP is especially developed for spraying application (similar to jetcrete). Binder and hardener are present in the mortar powder.</p> <p>Asplit® HSP is used as corrosion protection lining on larger buildings and tank surfaces that are dimensionally stable and free of torsion.</p>
<b>Asplit® K14</b>	Potassium silicate	<p>Asplit® K14 is a potassium silicate mortar with corresponding chemical and increased thermal resistance compared to conventional potassium silicate mortars.</p> <p>Asplit® K14 is used as heat- and chemical-resistant construction material for brick lining of refractory and acid-resistant bricks. It is suitable for all refractory brick linings where fireclay mortar cannot be used.</p>

**TIP TOP Oberflächenschutz Elbe**  
Christian-Heibel-Strasse 51  
56422 Wirges / Germany  
Phone: +49 (0) 26 02 - 949 50 0  
info@tiptop-elbe.de

→ [www.tiptop-elbe.com](http://www.tiptop-elbe.com)

Your local contact



// ONE BRAND // ONE SOURCE // ONE SYSTEM

// SERVICE  
// MATERIAL PROCESSING  
// SURFACE PROTECTION  
// AUTOMOTIVE

**REMA TIP TOP**  
Gruber Strasse 65 · 85586 Poing / Germany  
Phone: +49 (0)8121 707-100  
Fax: +49 (0)8121 707 -10 222  
info@tiptop.de  
[www.rema-tiptop.com](http://www.rema-tiptop.com)

